

REV	DESCRIPTION	DATE

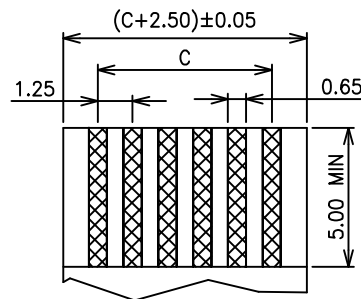
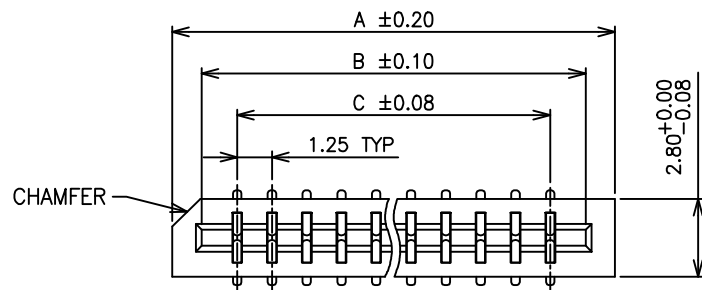

FPC/FFC T=0.30±0.05

NOTE:

- MATERIAL  
HOUSING: GLASS-REINFORCED THERMOPLASTIC UL 94V-0.  
CONTACT: COPPER ALLOY.  
PLATING: TIN PLATED OVER NICKEL.
- ELECTRICAL  
CURRENT RATING: 1.0AMP.  
DIELECTRIC WITHSTANDING VOLTAGE: 500V AC MIN.  
INSULATION RESISTANCE: 500MΩ MIN.  
CONTACT RESISTANCE: 30mΩ MAX.
- ENVIRONMENTAL  
TEMPERATURE RANGE: -25°C TO 85°C.
- PART NO.  
CNT-FPC125-XX-TSM-D0-550

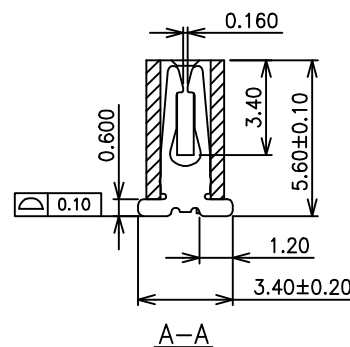
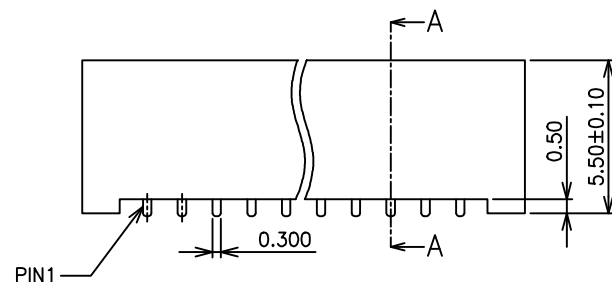

■ DIMENSION TABLE

Circuits	Dimension			Circuits	Dimension		
	A	B	C		A	B	C
2	5.90	3.80	1.25	20	28.40	26.30	23.75
3	7.15	5.05	2.50	21	29.65	27.55	25.00
4	8.40	6.30	3.75	22	30.90	28.80	26.25
5	9.65	7.55	5.00	23	32.15	30.05	27.50
6	10.90	8.80	6.25	24	33.40	31.30	28.75
7	12.15	10.05	7.50	25	34.65	32.55	30.00
8	13.40	11.30	8.75	26	35.90	33.80	31.25
9	14.65	12.55	10.00	27	37.15	35.05	32.50
10	15.90	13.80	11.25	28	38.40	36.30	33.75
11	17.15	15.05	12.50	29	39.65	37.55	35.00
12	18.40	16.30	13.75	30	40.90	38.80	36.25
13	19.65	17.55	15.00	31	42.15	40.05	37.50
14	20.90	18.80	16.25	32	43.40	41.30	38.75
15	22.15	20.05	17.50	33	44.65	42.55	40.00
16	23.40	21.30	18.75	34	45.90	43.80	41.25
17	24.65	22.55	20.00	35	47.15	45.05	42.50
18	25.90	23.80	21.25	36	48.40	46.30	43.75
19	27.15	25.05	22.50				

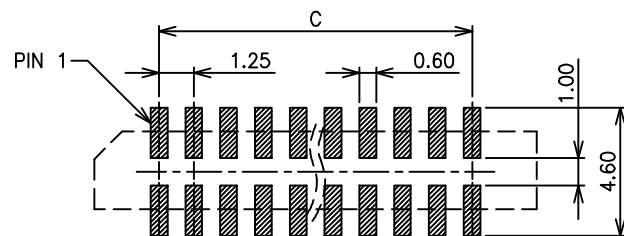

RECOMMENDED PCB LAYOUT

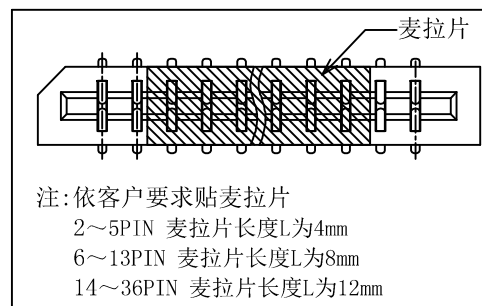

<p><b>CNT</b> 肯耐特电子有限公司</p>			GENERAL TOLERANCE		DRAWN	董道丽	DATE	20191011	DWG. NO.	TITLE
			X.° ±5°	X. ±0.30	CHECK	王芳芳	DATE	20191011	PART. NO.	
REV.	UNIT	SCALE			APPROVE	王元中	DATE	20191011	CNT-FPC125-XX-TSM-D0-550	
1.0	mm	1:1							FPC/FFC 1.25 PITCH NON ZIF TOP ENTRY DUAL CONTACT SMT TYPE-PARALLELED PCB LAYOUT	