

REVISION RECORD	
REV	DESCRIPTION
A/0	2007/08/10
A/1	Update edition
	2009/12/19

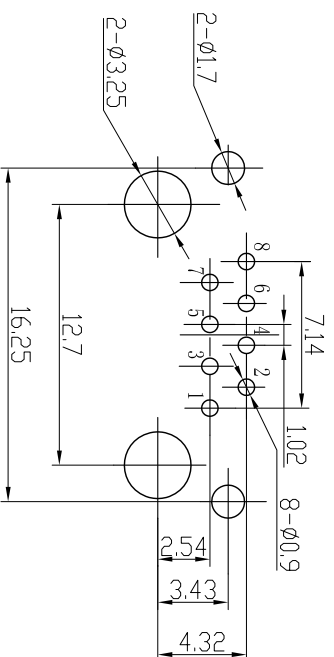

PC Board Layout

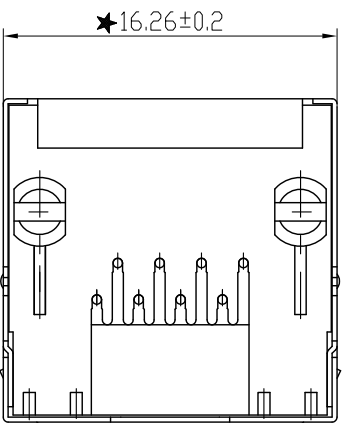
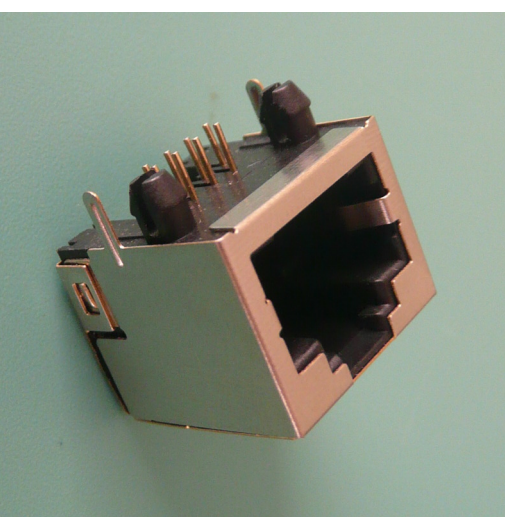
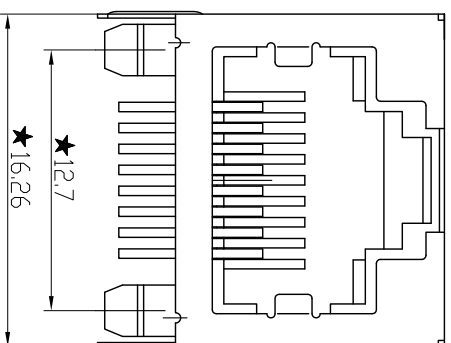
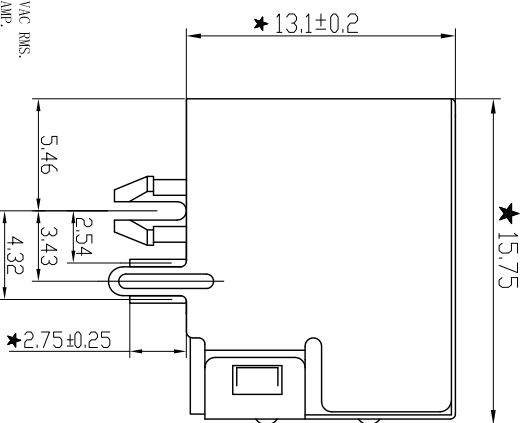
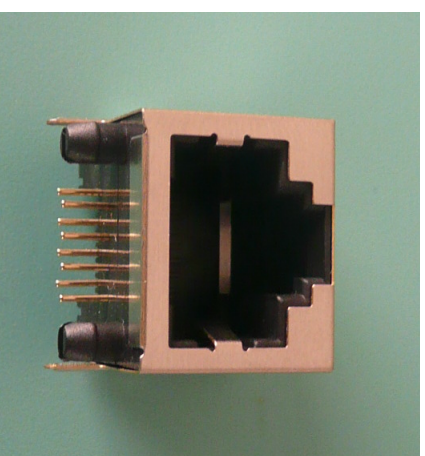

NOTES:

ELECTRICAL:

- VOLTAGE RATING : 125 VAC RMS.
- CURRENT RATING : 1.5 AMP.
- CONTACT RESISTANCE : 30 MILLIOHMS MAX.
- INSULATION RESISTANCE : 500 MEGOHMS MIN @ 500 VDC.
- DIELECTRIC STRENGTH : 1000 VAC RMS 50Hz or 60Hz, 1MIN.

MECHANICAL:

- HOUSING & INSERT MATERIAL : PBT UL94V-0.
- CONTACT MATERIAL : PBT UL94V-0.

SHIELD

- DIAMETER 0.45MM PHOSPHOR BRONZE
- GOLD PLATING OVER NICKEL.
- 0.20 ~ 0.25MM THICKNESS BRASS WITH TIN PLATED.

MATING/UNMATING FORCE

- 2.2KG.F MAX.
- 7.7KG.F MIN BETWEEN JACK AND PLUG.

REPECTION STRENGTH

- 600 CYCLES MIN.

OPERATING LIFE

- 600 CYCLES MIN.

ENVIRONMENTAL:

- STORAGE : -10°C ~ +40°C RELATIVE HUMIDITY<70%.
- OPERATION : -40°C ~ +70°C.

Remark:

- Tolerances Unless Otherwise Specified
 ± 0.25 , 0.0 ± 0.20 , 0.000 ± 0.10
- The mark with \star is the key inspection dimension for QC

TELL									
Fax									
Units	MM	Drawing		Material		Name		56LED 8P8C	
Scale	1 : 1	Check		SHIELD	H65V	不带灯 带屏蔽			
Rev'	A / 1	Approval		HOUSING	PBT	Part Number			
View		Date		PIN	Qsn6.5-0.1	File Name		E:\ \Drawing	

C N T 肯耐特电子有限公司